

QUICK START MANUAL

Mixers Equipped with London INSIGHT Mixer System

Includes information for the Following Models:

- Standard Mixer
- Paver Mixer

Publication No. 1596794

Rev. 11/2023

© 2023 London Machinery Inc. All Rights Reserved.

Disclaimer:

This manual must not be used to repair your Mixer. Repair information is available by calling London Machinery Inc. at (800) 265-1098.

The information in this Quick Start Manual will be your reference to initial start operation for this equipment. This manual is not intended to replace the Operator's Manual, also found with your vehicle, which must be read and thoroughly understood before operating this vehicle.

All information, illustrations, and specifications in this manual are based on the latest information available at the time of publishing. The illustrations used in this manual are intended as representative reference views only. Moreover, because of our continuous product improvement policy, we may modify information, illustrations, and/or specifications to explain and/or exemplify a product, service, or maintenance improvement. We reserve the right to make any change at any time without notice.

No part of this publication may be reproduced or used in any form by any means - graphic, electronic, or mechanical, including photocopying, recording, taping, or information storage and retrieval systems - without the written permission of London Machinery Inc.

1.0 Purpose of Manual

This manual is not intended to replace the Operator's Manual, also found with your Mixer, which must be read and thoroughly understood before operating this vehicle. This manual is intended as a quick start reference only. Read and follow all safety warnings and notices found in this manual and in the Operator's Manual.

If you have any questions about the content in this Quick Start Manual or in the Operator's Manual, contact London Machinery Inc. at 800-265-1098.

WARNING

The operator of this Mixer must be properly licensed and trained to operate this Mixer.

If you do not have the proper training and licensing to operate this Mixer, you are putting yourself and others at risk of serious injury or death.

If you are uncertain how to operate this Mixer, inform your supervisor or contact London Machinery Inc. Customer Service at 800-265-1098.

WARNING

Thoroughly understand the controls before operating the Mixer. Be sure everyone is clear of the area around the truck before operating the Mixer. Remain attentive at all times when operating the controls.

2.0 Scope

This manual provides information for use by the equipment operator under the following headings:

1. **Starting the Truck.** Includes operation for the start up of the truck and controls.
2. **Control Familiarization.** Includes control equipment and icon status identification.
3. **Drum Operation.** Includes drum control.
4. **Hopper and Chute Operation.** Includes basic information for operating the hopper and chute.
5. **Throttle Operation.** Includes rear throttle operation.
6. **Work Lighting.** Includes operation of the various work lighting options.
7. **Water Pump Operation.** Includes water pump control.

To order a replacement manual, call London Machinery Inc. at 800-265-1098.

1.0	STARTING THE TRUCK.....	1
2.0	CONTROL FAMILIARIZATION	2
2.1	Touch Screen Display	2
2.2	Speed/Direction Sensor Reading Screen	3
2.3	Drum Revolution Counters	4
2.4	Touch Screen Display Button Overview.....	5
2.5	Display Screen Status Icons.....	7
2.6	In-Cab Control Keypad.....	7
2.7	OMNEX Wireless Remote.....	9
2.8	Rear Control Pendant Keypad (If Equipped).....	11
3.0	DRUM OPERATION.....	12
3.1	Rotating the Drum with the In-Cab Control Keypad	12
3.2	Rotating the Drum with the OMNEX Wireless Remote	13
3.3	Rotating the Drum with the Rear Pendant Keypad (If Equipped)	14
3.4	Drum Stop Operation.....	15
3.5	Load Mode Enabled	16
3.6	Mix Mode Enabled	17
3.7	Constant Speed Mode Enabled.....	18
4.0	HOPPER AND CHUTE OPERATION (IF EQUIPPED).....	19
4.1	Hopper Operation	19



4.2 Chute Lock Operation..... 20

4.3 Chute Raise/Lower 21

4.4 Hopper, Chute Lock, and Chute Operation with Rear Pendant Control Keypad 22

5.0 THROTTLE OPERATION 23

6.0 WORK LIGHTING (IF EQUIPPED)..... 24

7.0 WATER PUMP OPERATION (IF EQUIPPED) 25

This Page Intentionally Left Blank

1.0 Starting the Truck

1. Ensure the battery box lockout switches are turned ON if equipped.
2. Walk around the entire mixer truck to ensure it is clear of obstructions and of non-operator personnel.
3. Start truck engine per chassis manufacturer's recommended starting practices.
4. In-cab control keypad will illuminate briefly (Figure 1) and the touch screen display will power up (Figure 2).

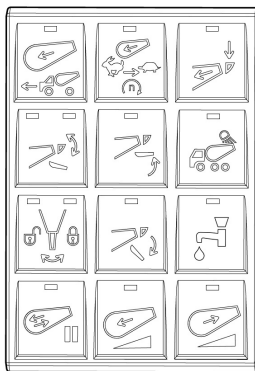

Figure 1. In-Cab Keypad

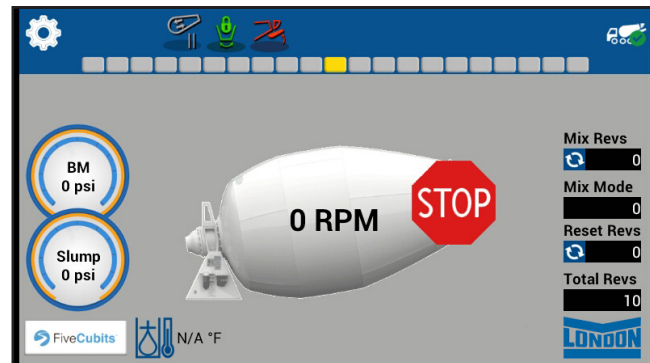

Figure 2

Operation

2.0 Control Familiarization

2.1 Touch Screen Display

This section will provide quick reference to the icons and functions of the display screen (Figure 3, Figure 4, and Figure 5). Please refer to the following pages for more detailed descriptions of these icons and functions.

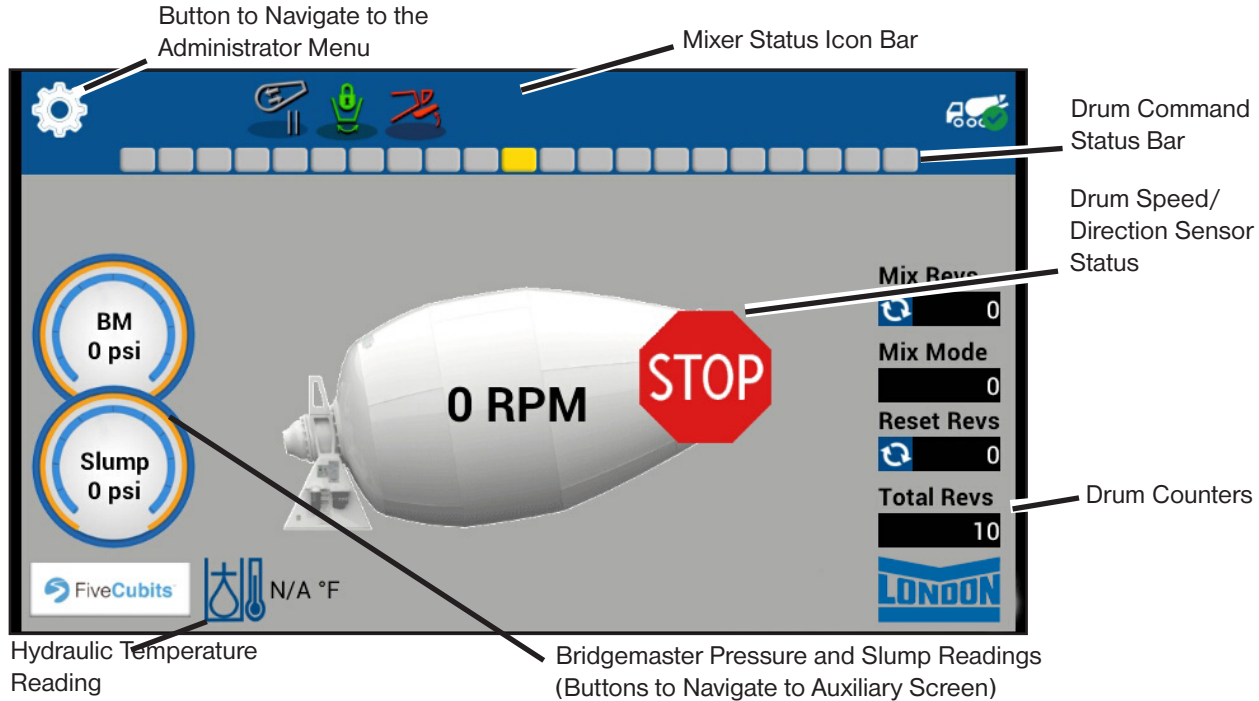
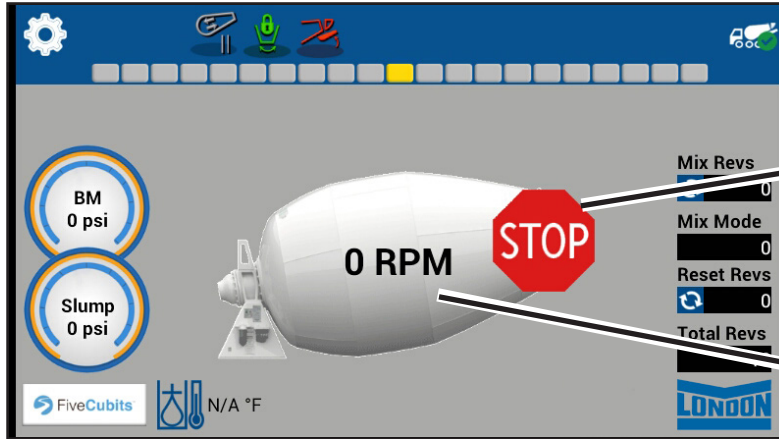

Figure 3

2.2 Speed/Direction Sensor Reading Screen



Signifies the Drum's Direction based on Sensor's Reading

Signifies the Drum's Speed Based on Sensor's Reading

Examples:

Direction: Charge
Speed: 4.8 Drum RPM

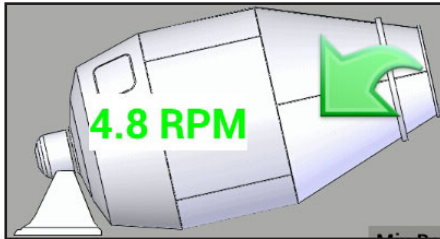

Direction: Stopped
Speed: 0 Drum RPM

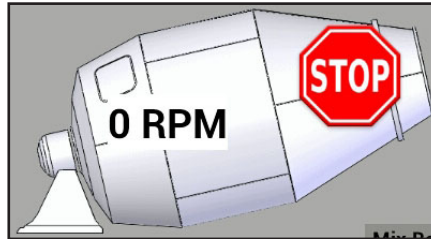

Direction: Discharge
Speed: 1.3 Drum RPM

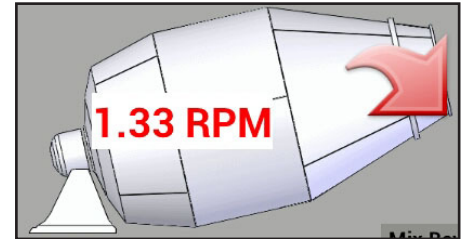

Figure 4

2.3 Drum Revolution Counters

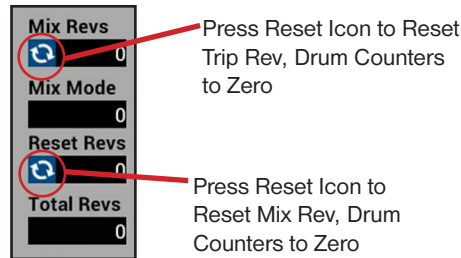
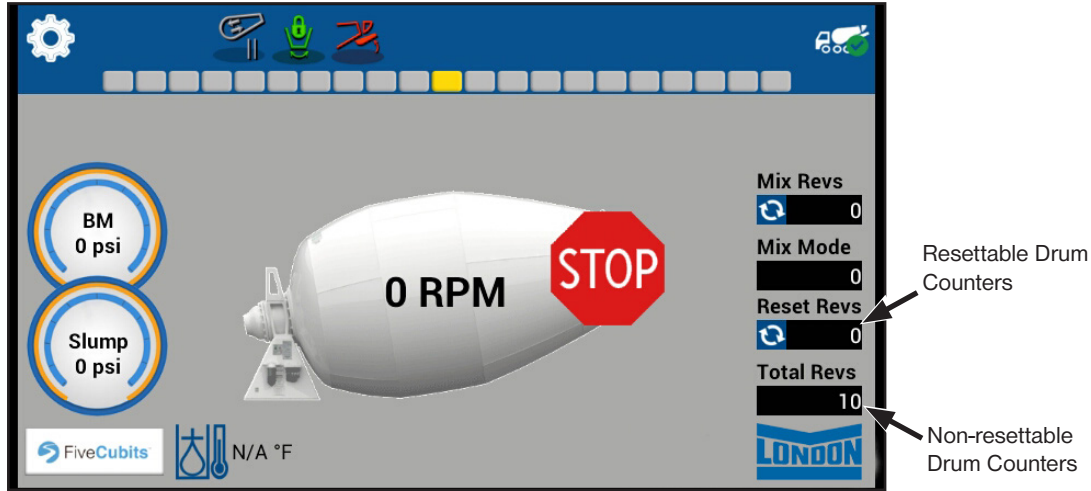

Figure 5

2.4 Touch Screen Display Button Overview

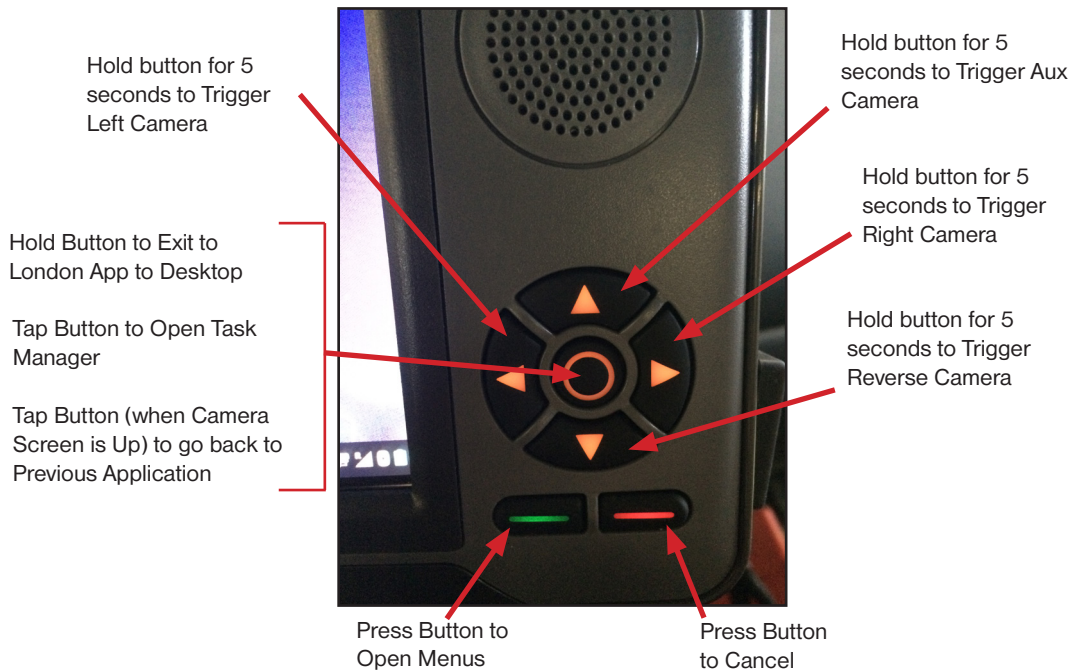
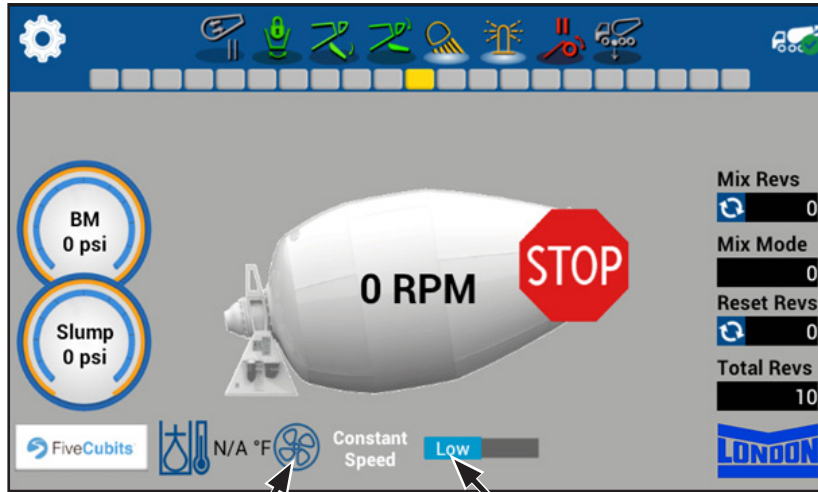

Figure 6



Press to manually turn Hydraulic Fan ON or OFF

Press to change Constant Speed setting from Low to High (Default: Low = 1.5 RPM, High = 3 RPM).

Figure 7

2.5 Display Screen Status Icons

These icons are part of the touch screen display to indicate the status of various functions.



Chute Locked



Chute Unlocked



Chute Down



Chute Up



Hopper Up



Hopper Down



Load Mode



Mix Mode



Work Lights On



Strobe Lights On



Add Water
(Optional
Equipment)



AdMix (Optional
Equipment)



Hydraulic
Temperature



Hydraulic Fan



Drum Charge



Drum Discharge

2.6 In-Cab Control Keypad

No.	Item	Description
1	Constant Speed Mode	Green LED when in constant speed mode. Turns drum in charge at preset speed (default = 1.5RPM) without being affected by changes in engine rpm. Constant speed will automatically engage if going over preset road speed.
2	Mix Mode	Green LED when in mix mode. Turns drum at preset speed for a preset number of revolutions by ramping engine speed.
3	Load Mode	Green LED when in load mode. Turns drum at maximum speed for loading purposes by ramping engine speed.
4	Hopper Up/ Down	Green LED when air hopper is DOWN. Red LED when air hopper is UP. Raises and lowers the charge hopper.
5	Chute Up	Green LED while button is pressed. Press and hold to raise the discharge chute.
6	Work and Perimeter Lights	Blue LED when work or perimeter lights are ON. Press once to turn on work lights, press 2nd time to turn on perimeter lights. Presses after 2nd time toggle perimeter lights on and off. Press and hold to turn off both work and perimeter lights.

No.	Item	Description
7	Chute Lock/ Unlock	Green LED when locked and Red LED when unlocked. Engages or disengages the chute lock.
8	Chute Down	Green LED while button is pressed. Press and hold to lower the discharge chute.
9	Water Pump On/ Off	Green LED when water pump is on. Turns water pump on or off.
10	Drum Pause/ Resume	Red LED when paused. Stops or resumes drum rotation.
11	Drum Charge	Green LED when charging. Pressing and holding speeds drum while charging (CW) and slows drum while discharging (CCW). Tap to incrementally adjust speed.
12	Drum Discharge	Red LED when discharging. Pressing and holding speeds drum while discharging (CCW) and slows drum while charging (CW). Tap to incrementally adjust speed.

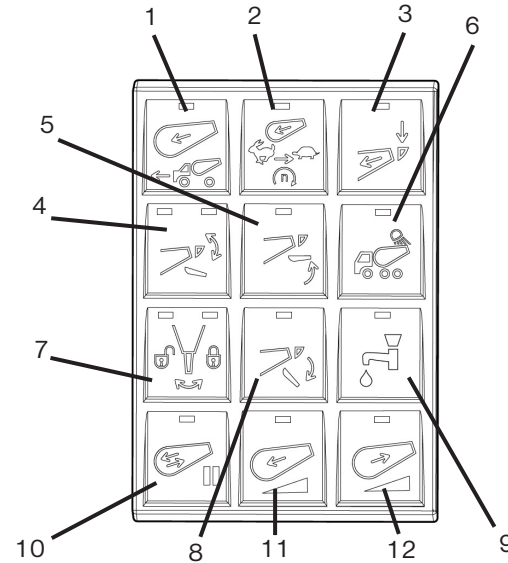

Figure 8

2.7 OMNEX Wireless Remote

The buttons present on the remote will vary, depending on the configuration of your Mixer.

No.	Control	Normal Use or Reading
1	Power On/Shift	Press to turn the radio remote ON. Press and hold to use green shift functions.
2	Drum Discharge	Pressing and holding speeds drum while discharging (CCW) and slows drum while charging (CW). Tap to incrementally adjust speed.
3	Throttle Decrease	Press and hold to decrease throttle/drum speed. Tap once to run at turtle preset engine speed (default = 600 RPM).
4	Mix Mode	While pressing and holding green shift button, press to engage or disengage mix mode. Turns drum at preset speed for mixing purposes by ramping engine speed for a preset number of revolutions.
5	Chute Down	Press and hold to lower the discharge chute.
6	Perimeter Lights On/Off	While pressing and holding green shift button, press to turn perimeter lights ON/OFF.
7	Hopper Up/Down	Press to raise or lower the charge hopper.
8	Drum Pause/Resume	Stops the drum rotation.

No.	Control	Normal Use or Reading
9	Water Pump On/Off	While pressing and holding green shift button, press to turn water pump ON/OFF.
10	Power Off	Press to turn the radio remote OFF. *Not an E-STOP.
11	Work Lights On/Off	While pressing and holding green shift button, press to turn work lights ON/OFF.
12	Constant Speed Mode	Press to engage or disengage constant speed mode. Turns drum in charge at preset speed (default = 1.5RPM) without being affected by changes in engine rpm.
13	Chute Lock/Unlock	Press to engage or disengage the chute lock.
14	Strobe Lights On/Off	While pressing and holding green shift button, press to turn strobe lights ON/OFF.
15	Chute Up	Press and hold to raise the discharge chute.
16	Load Mode	While pressing and holding green shift button, press to engage or disengage load mode. Turns drum at maximum speed for loading purposes by ramping engine speed.
17	Throttle Increase	Press and hold to increase throttle/drum speed. Tap once to run at rabbit preset engine speed (default = 1850 RPM).

Operation

No.	Control	Normal Use or Reading
18	Drum Charge	Pressing and holding speeds drum while charging (CW) and slows drum while discharging (CCW). Tap to incrementally adjust speed.

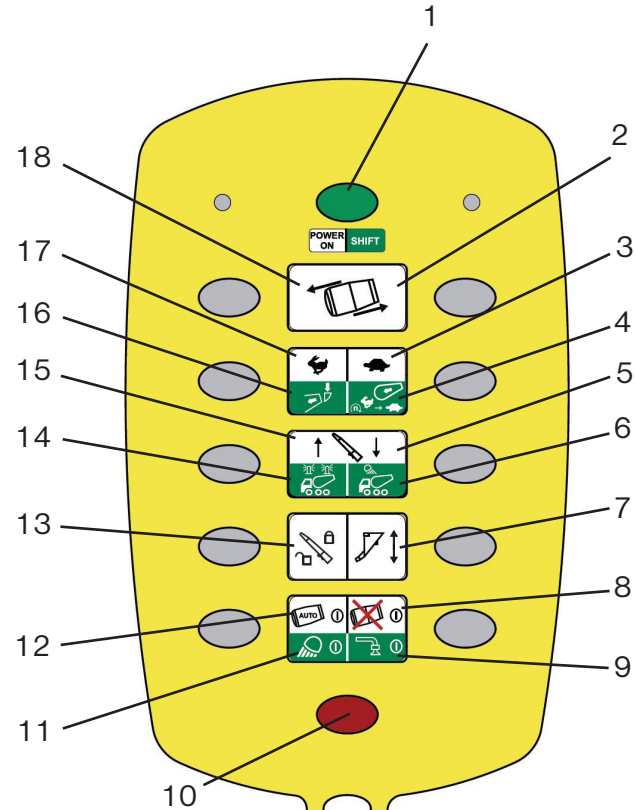

Figure 9

2.8 Rear Control Pendant Keypad (If Equipped)

The rear control pendant keypad controls some accessories and mixer functions (Figure 10). The operator can take the rear control pendant up the ladder platform for quick access to starting and stopping the drum. Buttons present on the control pendant vary depending on the configuration of your Mixer.

No.	Item	Operation
1	E-STOP	E-STOP on/off button. To reset, press and hold button for 5 seconds.
2	Throttle Down	Slows the engine throttle. Truck must be in Park/Neutral, parking brake must be set to active, and Cruise Control Switch turned on.
3	Throttle Up	Speeds engine throttle. Truck must be in Park/Neutral, parking brake must be set to active, and Cruise Control Switch turned on.
4	Hopper Up/Down	Green LED when air hopper is DOWN. Red LED when air hopper is UP.
5	Chute Up	Green LED while button is pressed.
6	Chute Lock/Unlock	Green LED when locked and Red LED when unlocked.
7	Chute Swing Left	Option Not Available
8	Chute Down	Green LED while button is pressed.
9	Chute Swing Right	Option Not Available
10	Drum Stop	Stops drum rotation.

No.	Item	Operation
11	Drum Charge	Speeds drum while charging and slows drum while discharging. Green LED while charging.
12	Drum Discharge	Speeds drum while discharging and slows drum while charging. Green LED while discharging.

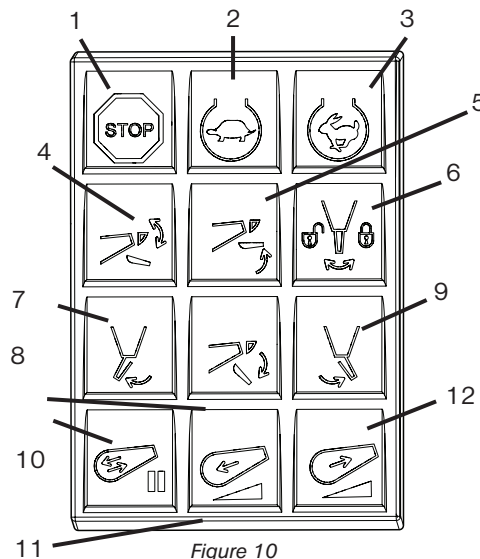

Figure 10

3.0 Drum Operation

3.1 Rotating the Drum with the In-Cab Control Keypad

1. Make sure the drum Start/Stop button indicator is OFF on the in-cab control keypad by pressing the button to toggle the light on/off (Figure 11).
2. Press the appropriate button, either Charge or Discharge on the in-cab keypad (Figure 11).
 - Drum Charge: Push to speed up drum while charging or to slow drum while discharging.
 - Drum Discharge: Push to speed up drum while discharging or to slow drum while charging.
3. Valve position proportionally affects drum speed. The more times the charge or discharge buttons are pressed on the keypad, the faster drum rotation speed will be.

NOTE: Charge and Discharge keypad button LED's will illuminate when the drum is rotating in the charge (CW) or discharge (CCW) direction.

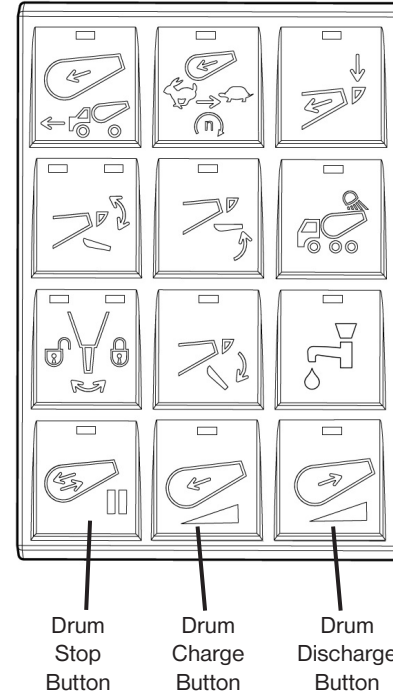

Figure 11

3.2 Rotating the Drum with the OMNEX Wireless Remote

1. If drum rotation is paused, press the drum stop button on the OMNEX Wireless remote to resume drum rotation and enable Charge and Discharge controls (Figure 12).
2. Press the appropriate button, either Charge or Discharge on the OMNEX Wireless Remote (Figure 12).
 - Drum Charge: Push to speed up drum while charging or to slow drum while discharging.
 - Drum Discharge: Push to speed up drum while discharging or to slow drum while charging.
3. Valve position proportionally affects drum speed. The more times the charge or discharge buttons are pressed on the remote, the faster drum rotation speed will be.

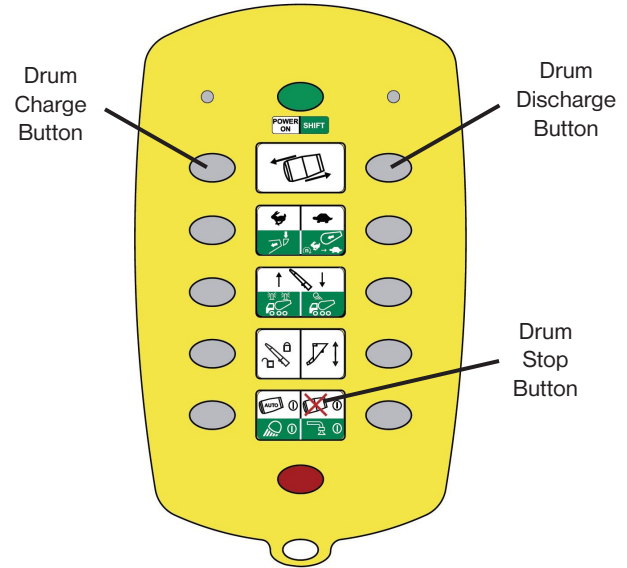

Figure 12

3.3 Rotating the Drum with the Rear Pendant Keypad (If Equipped)

1. Make sure the drum Start/Stop button indicator is OFF on the rear pendant keypad by pressing the button to toggle the light on/off (Figure 13).
2. Press the appropriate button, either Charge or Discharge on the rear pendant keypad (Figure 13).
 - Drum Charge: Push to speed up drum while charging or to slow drum while discharging.
 - Drum Discharge: Push to speed up drum while discharging or to slow drum while charging.
3. Valve position proportionally affects drum speed. The more times the charge or discharge buttons are pressed on the keypad, the faster drum rotation speed will be.

NOTE: Charge and Discharge keypad button LED's will illuminate when the drum is rotating in the charge (CW) or discharge (CCW) direction.

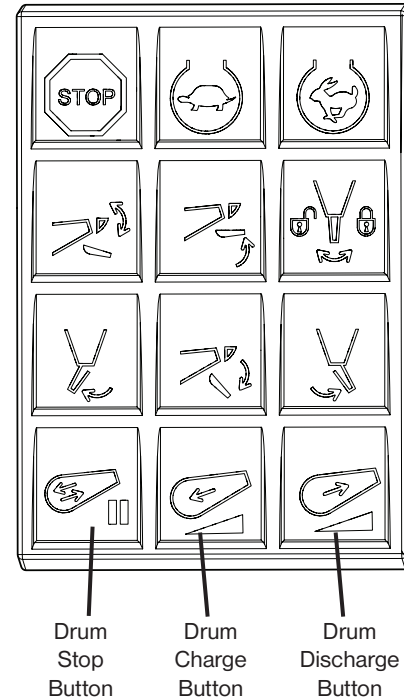

Figure 13

3.4 Drum Stop Operation

The in-cab control keypad, rear pendant keypad, and OMNEX Wireless Transmitter have a button that will stop drum operation.

1. The drum STOP button (Figure 14, Item 1) must be OFF (this means the indicator light must be OFF) upon truck startup for drum rotation to be enabled.
 2. To stop drum rotation at any time while the drum is turning in either direction, press the STOP control button at any control station. The button indicator will illuminate red and the drum will stop rotation.
 3. To restart drum rotation, press the STOP control button. The button indicator light will turn OFF and the drum will restart in the same direction and rotation speed prior to the stop event.
- If drum was paused while in discharge, pressing the charge button will reset the drum RPM to zero and turn off the discharge keypad button's red LED. When drum stop button is pressed again to resume drum rotation, the drum will not return to the previous discharge speed.

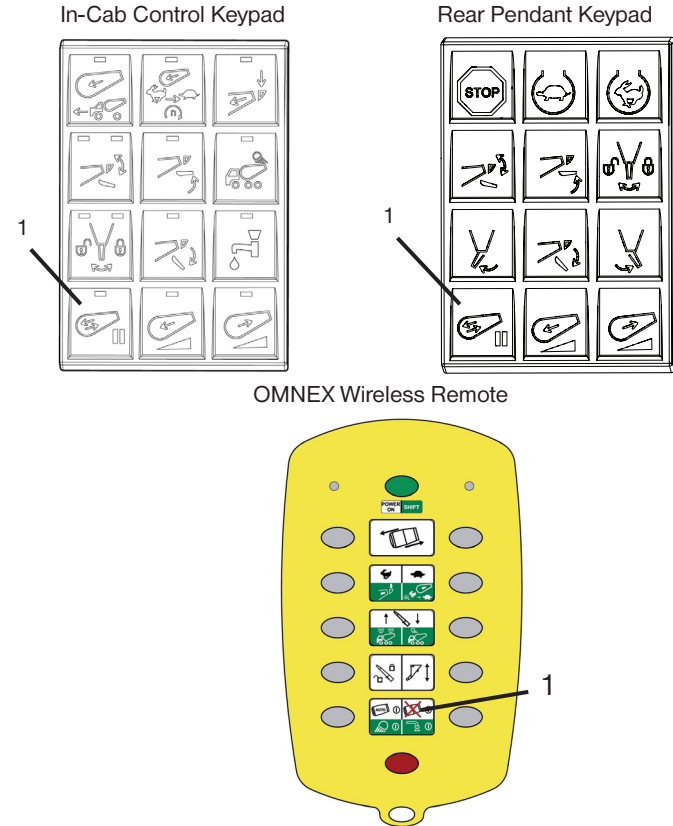

Figure 14

3.5 Load Mode Enabled

The LOAD function is enabled using the in-cab control keypad or the OMNEX wireless remote . The LOAD function allows for one-touch operation of the loading function. When pressed, the engine RPM will go to the full preset and the drum speed will accelerate to 18 RPM. The button indicator will illuminate and the drum control screen will show the LOAD icon on the touch screen display (Figure 15).

1. Position the Mixer under the loading boot.
2. **Truck must be in Park/Neutral, parking brake must be set to active, and Cruise Control Switch turned on.**
3. To enable LOAD function, press the LOAD button on the in-cab control keypad (Figure 15, Item 1), or while holding the green shift key, press the OMNEX wireless remote button (Figure 15, Item 2).
4. Truck engine will ramp to full preset and the drum will accelerate to full CHARGE.
5. When loading is complete, press the LOAD button again. The system will default to Constant Speed mode preset (the Constant Speed indicator will illuminate) (Figure 15, Item 3).

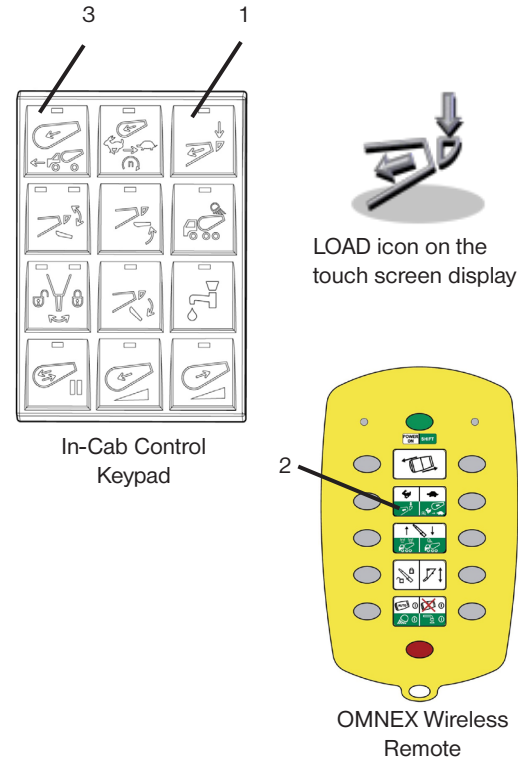
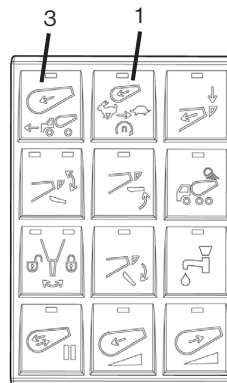

Figure 15

3.6 Mix Mode Enabled

The MIX function is enabled using the in-cab control keypad or OMNEX wireless remote. The MIX function allows for one-touch operation of the mixing function while at the slump rack or prior to job pour. When pressed, the engine RPM will go to the full preset and the drum speed will accelerate to the preset Mix RPM for a preset number of drum revolutions. The button indicator will illuminate and the drum control screen will show the MIX icon on the touch screen display (Figure 16).

1. **Truck must be in Park/Neutral, parking brake must be set to active, and Cruise Control Switch turned on.**
2. To enable MIX function, press the MIX button on the in-cab control keypad (Figure 16, Item 1), or while holding the green shift key, press the OMNEX wireless remote button (Figure 16, Item 2).
3. Truck engine will ramp to full preset and drum will accelerate to MIX RPM in the charge direction ONLY for a preset number of revolutions (set by Fleet Manager).
4. When mixing revolutions reach the preset, the MIX mode will cancel and the engine and drum will slow to IDLE and CONSTANT SPEED respectively. The system will default to Constant Speed mode preset (the constant speed indicator will illuminate) (Figure 16, Item 3).



In-Cab Control Keypad



MIX icon on the touch screen display

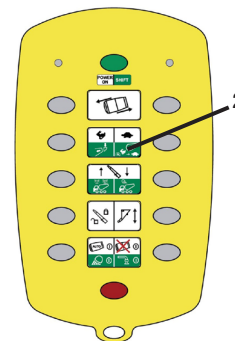

OMNEX Wireless Remote

Figure 16

3.7 Constant Speed Mode Enabled

The Constant Speed function is enabled using the in-cab control keypad or Omnex remote. The Constant Speed function allows for one-touch operation of a preset slow charge drum speed (default = 1.5 RPM) for transport to the job site without the need to manually adjust the controls with changing engine RPMs. The Constant Speed value can be changed from a Low to a High speed setting (default = 3 RPM) by tapping the touchscreen Low/High Button (Figure 17, Item 2).

NOTE: Constant Speed will automatically engage when either the LOAD or MIX modes are cancelled or a preset road speed is reached (programmable) or shut off.

1. To manually enable CONSTANT SPEED mode, press the CONSTANT SPEED button on the in-cab control keypad, or press the OMNEX wireless remote button (Figure 17, Item 1).

NOTE: The rear throttle controls are disabled while this mode is activated.

2. To turn off, press the CONSTANT SPEED button again.

NOTE: If Constant Speed is turned off while driving over preset road speed, constant speed mode will automatically turn on again after a preset time value (default = 1 min).

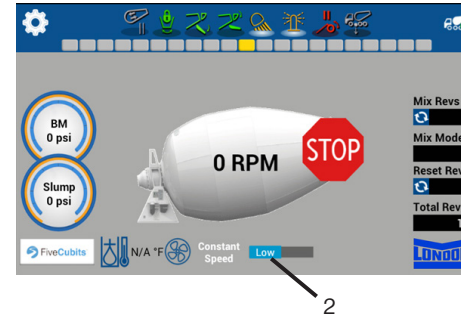
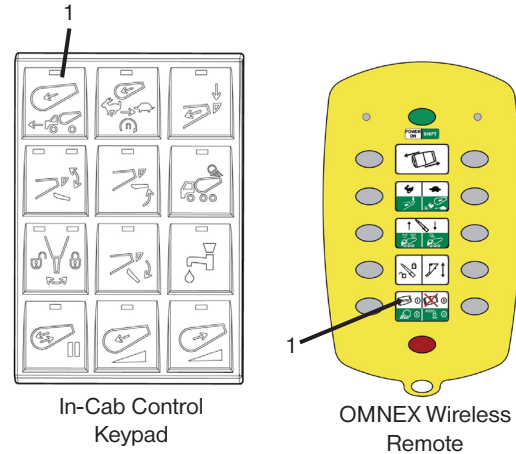

Figure 17

4.0 Hopper and Chute Operation (If Equipped)

4.1 Hopper Operation

The movement of the air hopper is enabled on the in-cab control keypad or the OMNEX wireless remote. Hopper UP indicates the hopper is in a position to allow the concrete mixture to discharge. Hopper DOWN indicates the hopper is in a position to fill the drum with the mixture.

1. Press the HOPPER button on the in-cab control keypad or the OMNEX wireless remote (Figure 18). The button indicator will illuminate red for Hopper UP and green for Hopper DOWN. Additionally, the home/drum control screen will show either the Hopper UP icon or the Hopper DOWN icon.

OPERATIONAL NOTE: Upon truck startup, cycle the Hopper DOWN button until indicator light shows GREEN on the function button.

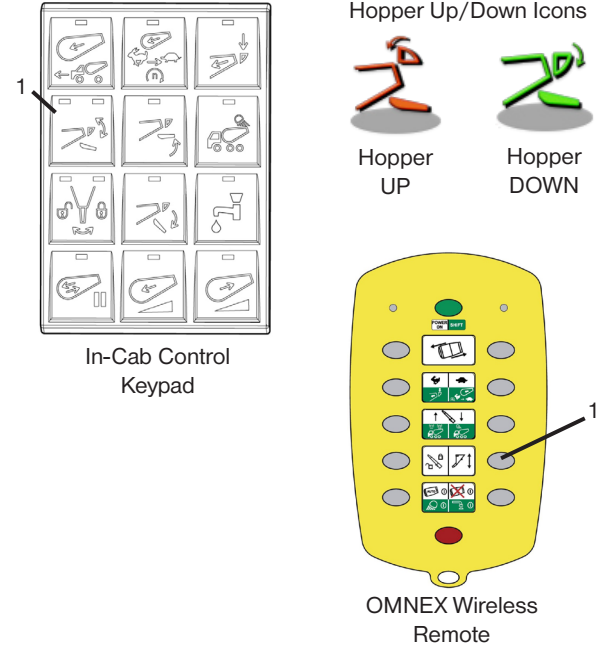

Figure 18

4.2 Chute Lock Operation

The pneumatic chute lock/unlock is enabled on the in-cab control keypad or the OMNEX wireless remote. CHUTE UNLOCKED indicates the chute is not locked into position and may move freely when movement is undesired. CHUTE LOCKED indicates the chute is locked into position and will not move until unlocked.

1. Press the CHUTE LOCK button on the in-cab control keypad (Figure 19) or the OMNEX wireless remote. The button indicator will illuminate red for CHUTE UNLOCKED and green for CHUTE LOCKED. Additionally, the drum control screen will show either the CHUTE UNLOCKED icon or the CHUTE LOCKED icon.

OPERATIONAL NOTE: Upon truck startup, cycle the Chute LOCKED button until indicator light shows GREEN on the function button.

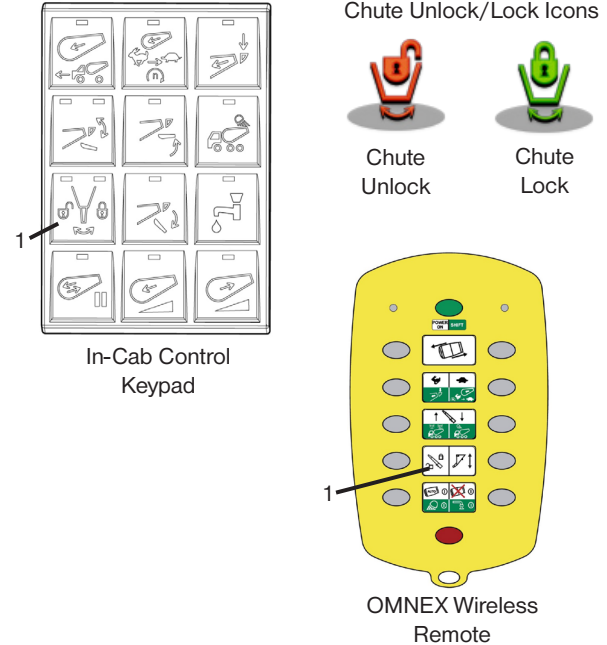

Figure 19

4.3 Chute Raise/Lower

The chute raise and lower is enabled on the in-cab control keypad or the OMNEX wireless remote (Figure 20).

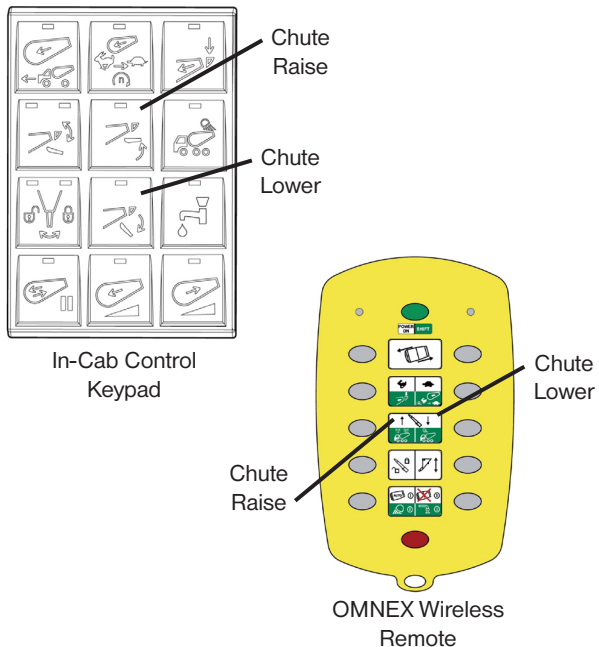

Figure 20

Operation

4.4 Hopper, Chute Lock, and Chute Operation with Rear Pendant Control Keypad

Hopper Operation: Push the Hopper button to raise/lower air hopper (option) (Figure 21, Item 1).

Chute Lock: Push the Chute Lock button to lock/unlock air chute lock (Figure 21, Item 2).

Chute Raise Operation: Push the Chute Raise button to raise chute (Figure 21, Item 3).

Chute Lower Operation: Push the Chute Lower button to lower the chute (Figure 14, Item 4).

OPERATIONAL NOTE: Upon truck startup, cycle the Hopper button and the Chute LOCK button until “Hopper DOWN” and “Chute LOCK” icons are displayed on the touch screen.

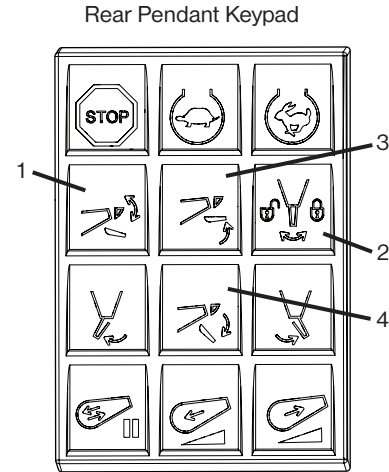

Figure 21

5.0 Throttle Operation

The throttle controls are on the Rear Pendant Keypad or OMNEX Wireless Remote (Figure 22).

To use the Throttle Controls:

- **Make sure the parking brake is set and the Mixer is in NEUTRAL**
 - Drum STOP must be OFF (drum must be turning)
 - Constant Speed must be OFF
1. ***Press and hold*** the Throttle Raise button (rabbit icon) to ramp engine RPM up.
 2. ***Press and hold*** the Throttle Lower button (turtle icon) to ramp engine RPM down.
 3. ***Tap*** the Throttle Raise button (rabbit icon) to ramp to rabbit preset engine speed (Default = 1850 RPM).
 4. ***Tap*** the Throttle Lower button (turtle icon) to ramp to turtle preset engine speed (Default = 600 RPM).

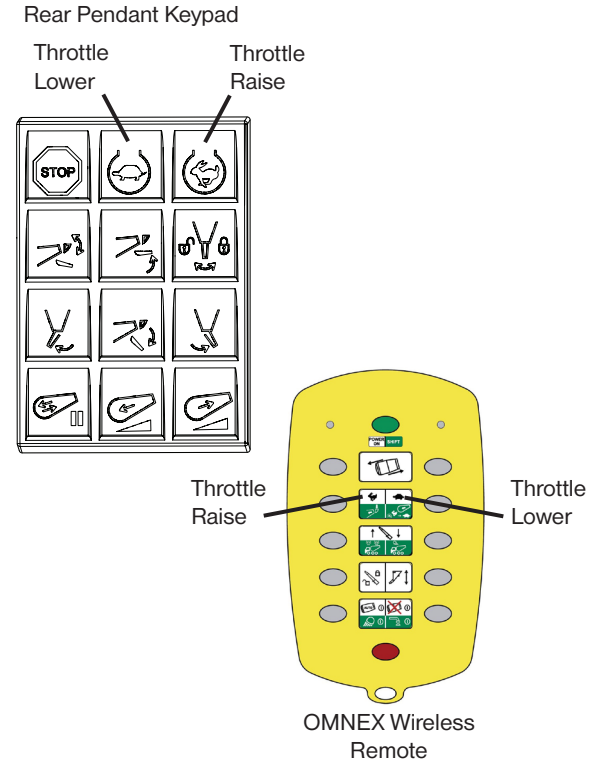

Figure 22

Operation

6.0 Work Lighting (If Equipped)

Work lighting operation is controlled by the in-cab control keypad or the OMNEX wireless remote (Figure 23). The touch screen monitor only displays whether the work lighting is turned on or off.

Using In-Cab Keypad to turn lights ON/OFF:

Press once to turn on work lights. Press 2nd time to turn on perimeter lights. Presses after 2nd time toggle perimeter lights on and off. Press and hold to turn off both work and perimeter lights.

NOTE: Work lights will not turn off if the reverse function forces the lights on.

Using OMNEX Wireless Remote to turn lights ON/OFF:

While pressing and holding the green shift button, press the strobe lights, perimeter lights, or work lights button to turn required lights ON/OFF (Figure 23).

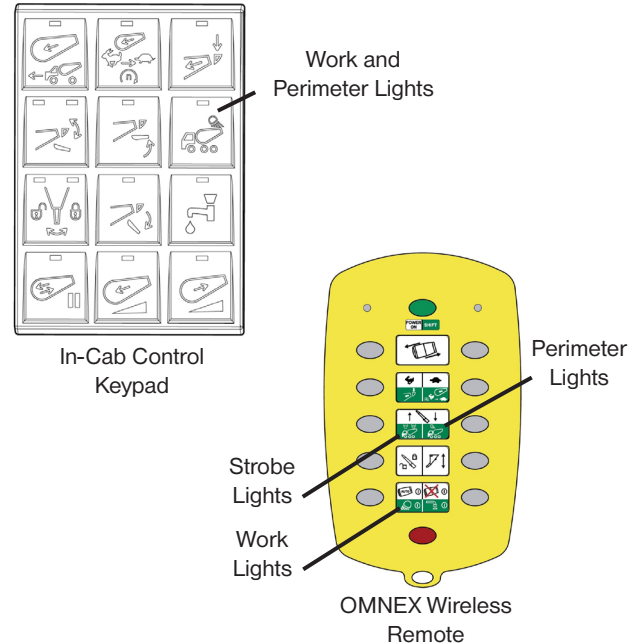

Figure 23

7.0 Water Pump Operation (If Equipped)

Water pump operation is controlled by the in-cab control keypad or the OMNEX wireless remote (Figure 24).

Using In-Cab Keypad to turn water pump ON/OFF:

Press the water pump button on the in-cab keypad to turn the pump ON or OFF. The button indicator will illuminate green when pump is ON.

Using OMNEX Wireless Remote to turn water pump ON/OFF:

While pressing and holding the green shift button on the OMNEX wireless remote, press water pump button to turn pump ON or OFF.

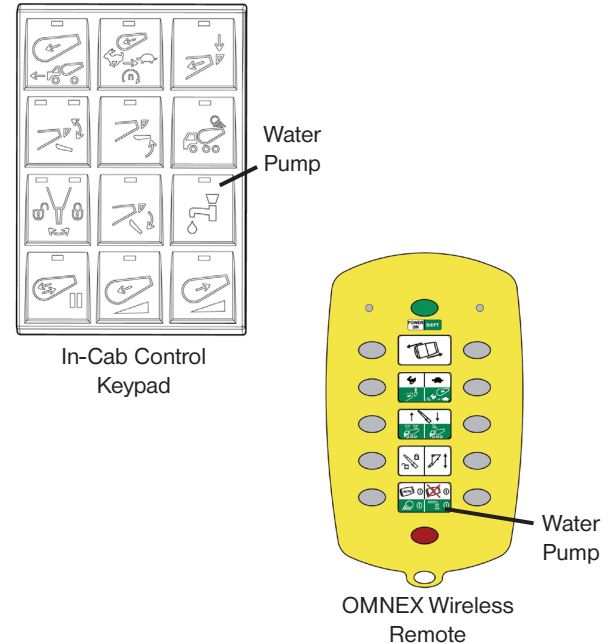

Figure 24



(800) 265-1098
lmi.ca